

# VCI 180 Mini-Master VCI 250 Master-Tech



High performance,  
latest technology,  
reasonable in price

- Continuous and intermittent motion
- For free flowing, pourable or paste-like products
- For all heatsealable wrapping materials and PE films
- For pillow, gusseted or block bottom bags with a volume of up to 6000 cm<sup>3</sup>

A fresh breeze in bag packaging



# VCI 180 Mini-Master / VCI 250 Master-Tech

## A versatile high-speed machine

The VCI 180 Mini-Master / VCI 250 Master-Tech is a continuous and intermittent motion packaging machine for medium size bags.

The VCI 180/VCI 250 provides the user with a vertical form, fill and seal machine that has convincing features and a unique cost-benefit ratio offering superior production conditions. This high-speed machine is designed for efficient, high-capacity production of free flowing, pourable or paste-like products in the food and non-food sectors. It is able to operate in continuous or intermittent mode depending on the packaging application.

All heat-sealable wrapping materials as well as PE-films can be used with the VCI to produce pillow, gusseted and block bottom bags with a volume of up to 6000 cm<sup>3</sup>.

### Gentle product handling and efficient operation

While the bagger continuously pulls film from the roll stock and forms it into a tube, continuous motion sealing tools apply heat to the seal areas to form the vertical seal and the cross seal of the bag. Each time a cross seal for a new bag is made, the bagger calls for a charge of product from a feeding unit. While the correct amount of product drops into the forming tube, the filled bag is advanced by a special draw-down system to receive a top seal. As the top seal is made, the finished bag gets cut off from the next bag to be filled. All machine movements are controlled with servomotors. A key feature of the VCI is its nearly wear- and maintenance-free operation.

### Easy operation, convenient resetting

The user-friendly operation of the VCI 180/VCI 250 is especially worth mentioning. All machine functions are monitored and controlled via a programmable control system. Up to 100 production programs can be stored in the memory. A color touch screen serves as HMI (human machine interface) where the user has control over all necessary machine functions and parameters. The logic control prevents out of range entries.

The fast and easy changeover to a different film or bag size is especially convenient on the VCI, where all adjustments and settings can be made from the front of the machine.

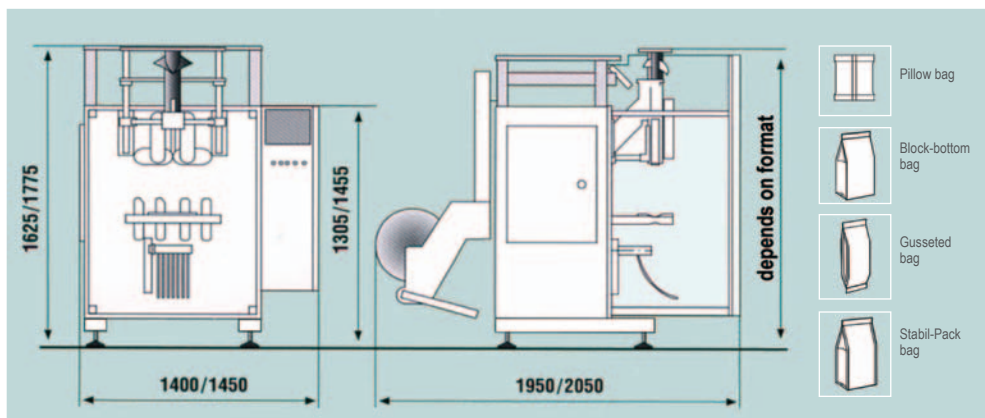

| Technical Data      | VCI 180 Mini-Master           | VCI 250 Master-Tech           |
|---------------------|-------------------------------|-------------------------------|
| Machine height      | 1625 mm                       | 1775 mm                       |
| Machine width       | 1400 mm                       | 1450 mm                       |
| Machine depth       | 1950 mm                       | 2050 mm                       |
| Bag width           | 50-180 mm                     | 50-250 mm                     |
| Bag length          | 80-350 mm                     | 80-450 mm                     |
| Filling volume      | 2000 cm <sup>3</sup>          | 6000 cm <sup>3</sup>          |
| Film reel diameter  | 400 (600) mm                  | 400 (600) mm                  |
| Performance*        | bis 180 bags/min              | bis 150 bags/min              |
| Air requirements**  | 40 l/min at 6 bar             | 40 l/min at 6 bar             |
| Energy requirements | 4.5 kW                        | 4.5 kW                        |
| Power supply        | 230/400 V, 3 Ph., N, 50/60 Hz | 230/400 V, 3 Ph., N, 50/60 Hz |
| Protection system   | IP 54                         | IP 54                         |
| Weight              | 900 kg                        | 1000 kg                       |
| Standard colour     | RAL 1013 / RAL 9007           | RAL 1013 / RAL 9007           |

\*) depending on product and wrapping material, \*\*) depending on performance

Subject to technical modifications

### User-friendly features, convincing benefits

- Continuous or intermittent mode upon customer's choice
- Nearly wear- and maintenance-free operation
- Quick and easy size change
- Compact, operator-friendly design
- Programmable control
- Color touch screen
- Electronic control for bag length
- Photoeye control for accurate eyemark reading of printed films
- Servo driven cross sealing station
- Adjustable sealing time
- Adjustable stroke of cross sealing jaws (depending on bag size)
- Servo driven film draw-down belts

- Vertical sealbar pressure adjustment with digital indicator
- Motor for film tracking adjustment
- Resistant finish on machine housing and electrical control cabinet
- Service unit for compressed air
- Operator-friendly safety doors with locking magnets

### Customer-specific options

- Impulse sealing system for PE
- Gusseting device
- Automatic film tracking
- Corner creasing on forming tube
- Offset vertical seal
- Stainless steel design
- Modem for data transmission
- 4 corner sealing system (Stabil-Pack)



### WOLF Verpackungsmaschinen GmbH

Bettenhäuser Str. 3, D-35423 Lich-Birklar

Phone +49 (0)64 04-91 82-0, Fax +49 (0)64 04-91 82-83

E-Mail: [contact@wolf-pack.de](mailto:contact@wolf-pack.de); [www.wolf-pack.de](http://www.wolf-pack.de)